



BHAGWATI

CRANES

PRECISION, QUALITY & EFFICIENCY WITH FLEXIBILITY

“LIFTING SOLUTIONS WORLDWIDE”

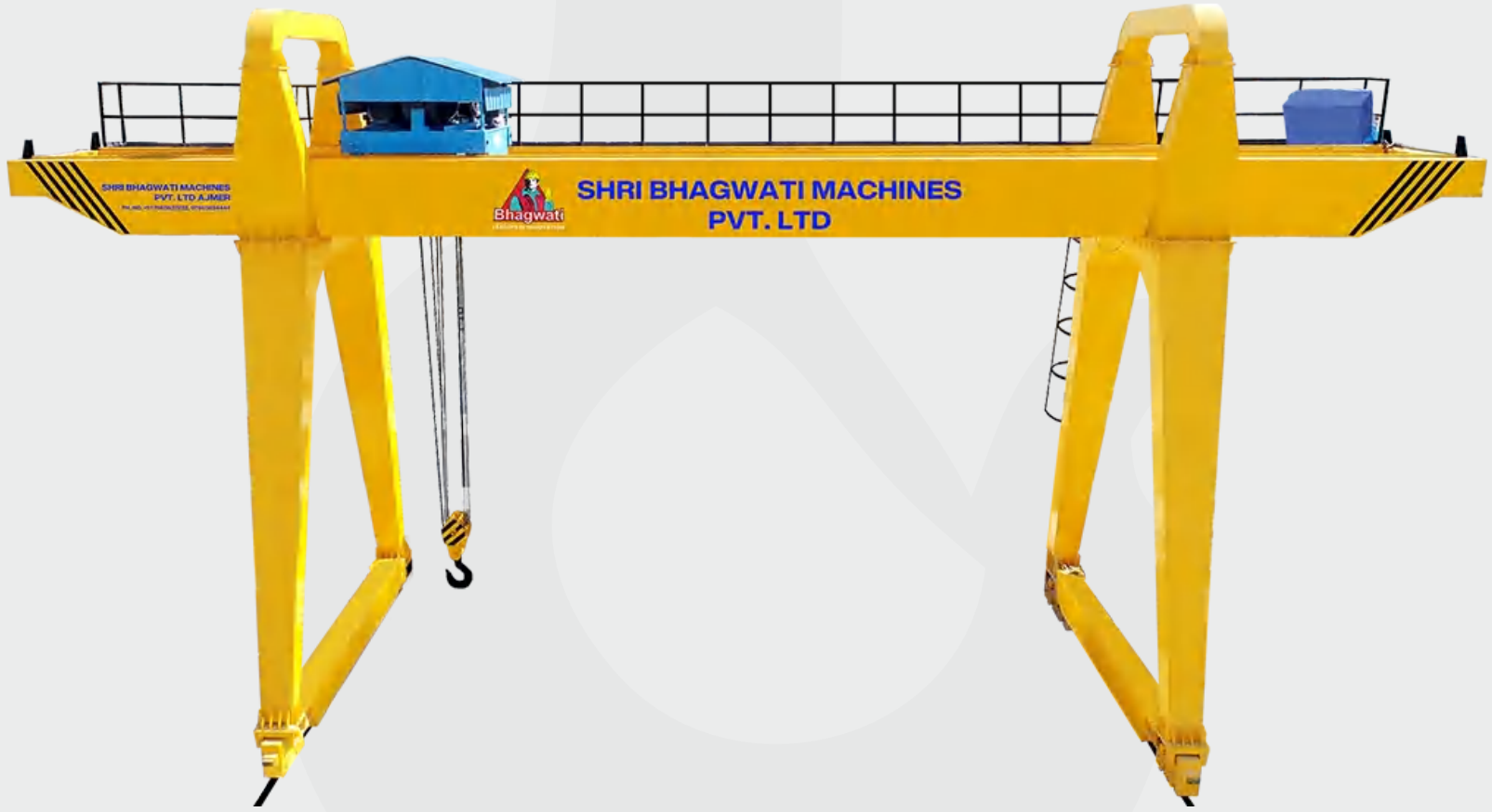

SHRI BHAGWATI MACHINES
PVT. LTD AJMER
INDIA



SHRI BHAGWATI MACHINES
PVT. LTD

CHAIN HOIST

ADVANTAGES OF THE BHAGWATI'S CRANE:

MANUAL CHAIN HOIST

- ▶ Range 1 T to 10T.
- ▶ Zero operating cost.
- ▶ light & medium duty applications.
- ▶ Manual operation.



ELECTRIC TROLLEY

- ▶ Range 0.5 T to 10 T.
- ▶ Operated by electric motor.
- ▶ Suitable for wide range of flange width.
- ▶ Low operating cost and long service life.



GEARED TROLLEY

- ▶ Range 0.1 T to 6 T.
- ▶ Electric trolley range.



RATCHET LEVER HOIST

- ▶ Range 0.5 T to 9 T.
- ▶ Operated by manually.
- ▶ Hook suspended lever hoist.
- ▶ Low operating cost and long service life.



PUSH PULL TROLLEY

- ▶ Range 0.5 T to 5 T.



BER SERIES (RANGE 0.5 T to 5 T)

- ▶ Range 0.5 T to 5 T.
- ▶ Long life friction clutch.
- ▶ Durable upper & lower limit switches
- ▶ Extreme duty fan cooled motor.
- ▶ Inverter (optional).
- ▶ Ergonomic push button pendant.
- ▶ Hooks suspension & electric trolley



BES SERIES

- ▶ Range 1 T to 7.5 T.
- We offer our customers the best quality of BES series hoist with exclusive series that will help in the lifting of different ranges of weight.
- ▶ These hoist electrically controlled and are easy to handle and maintenance
- Hook suspended and electric trolley.



BBES SERIES (RANGE 10 T to 30 T)

- ▶ Range 10 T to 30 T.
- ▶ Robust and heavy duty chain hoist
- Hook suspended and electric trolley.
- ▶ Faster lifting speeds.
- ▶ Wider range of lifting capacity.
- ▶ Pendant or controller operated.



CRANES

JIB CRANES

- ▶ JIB crane Range - 0.5T to 3T, Arm Up to 4 Mtr.
- ▶ Can be used freely in three dimensional space.
- ▶ Jib crane design with special structure, High safety & reliability with high efficiency which can save your energy & time.
- ▶ Cover small working area, easy to operate, flexible, economic & durable.
- ▶ Customized Crane optional available.



UNDER SLUNG CRANE

- ▶ SWL up to 0.5T to 10T.
Crane track suspended from ceiling optimal side approach dimensions maximizes available building width.
- ▶ Highly durable & sturdy designs offer superior functionality, high load bearing capacity with long service life.
- ▶ We offers under slung crane with manual hoist, electric chain hoist & electric wire rope hoist.

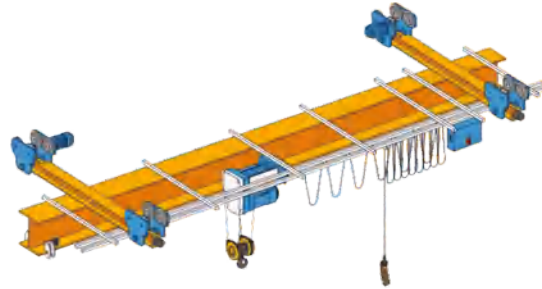

SINGLE & DOUBLE GIRDER EOT CRANE

- ▶ Single Girder EOT Crane Range - 1T to 10T, Span Up to 30 Mtr.
- ▶ Double Girder EOT Crane Range - 3T to 80T, Span Up to 30 Mtr.
- ▶ Light weight and compact design minimizing building load & Space.
- ▶ Suitable for light, medium & Heavy duty workshop applications.
- ▶ High rigidity with minimum dead weight.
- ▶ Dual speeds for CT, LT & Hoisting.
- ▶ DIN & ISO international standard cranes.
- ▶ IP 56/IP 65 Panel Enclosure.
- ▶ Wide range of classification up to M8 duty cranes.
- ▶ Easy for assembly and dismantle.
- ▶ No special to required.



GANTRY CRANE

ADVANTAGES OF THE **BHAGWATI'S CRANE:**

GOLIATH / GANTRY CRANE

- ▶ Single Girder Goliath Range - 1T to 10T, Span Up to 30 Mtr.
- ▶ Double Girder Goliath Range - 5t to 150T, Span Up to 30 Mtr.
- ▶ Outstanding Crane geometry ensures excellent travel characteristics and minimize wear and tear of CT & LT wheels & runway.
- ▶ Unique safe flange beam joint suitable to normal size container/shipment.
- ▶ Higher service/safety factor crane duty components.
- ▶ Din & ISO international standard cranes.
- ▶ IP 56/IP 65 Panel Enclosure.
- ▶ FEM rested Robust design.

CRANE KIT

- ▶ End Carriages Hoist.
- ▶ Festoon System.
- ▶ Remote Control / Cable Pendant.

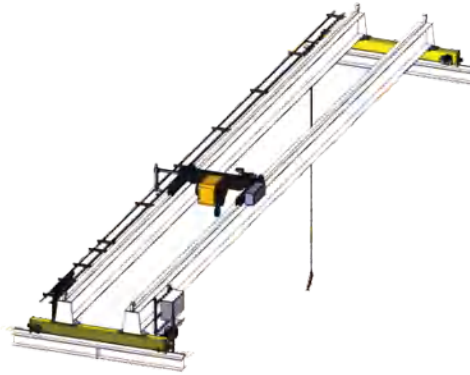

ELECTRIC WIRE ROPE HOIST

ADVANTAGES OF THE BHAGWATI'S CRANE:

BEWH SERIES

- ▶ Single Girder hoist Range, 1T to 12.5T.
- ▶ European design.
- ▶ Compact design & aesthetic look.
- ▶ Minimize hook approach.
- ▶ Classic wire rope hoist durable, efficient and easy to handle.
- ▶ Suitable for wide range of flange width.



BVH SERIES

- ▶ Single Girder hoist Range, 1T to 12.5T.
- ▶ Japanese design.
- ▶ Higher reliable breaking system.
- ▶ Efficient maintenance is possible.
- ▶ The hoist composed rotational system with unitized break, motor, drum, reduction gear and auxiliary break.
- ▶ Hoisting motor thermal protection



BEWH SERIES

- ▶ Double Girder hoist Range, 3T to 80T.
- ▶ European design.
- ▶ Compact & low headroom design.
- ▶ Minimize hook approach.
- ▶ Equipped with high safety features.



BIH SERIES

- ▶ Single Girder hoist Range, 1T to 12.5T.
- ▶ Double Girder hoist Range, 3T to 150.5T.
- ▶ Indian design.
- ▶ Compact & low headroom design.
- ▶ Minimize hook approach.
- ▶ Equipped with high safety features.
- ▶ Customization is possible as per customers requirement with following IS standard.



SPARE PARTS

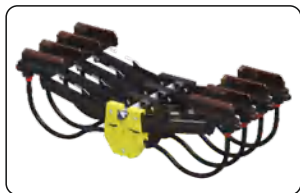

CURRENT COLLECTOR



THRUSTER BRAKE



DISC BRAKE



SOLENOID BRAKE



C RALL FESTOON SYSTEM



EM BRAKE



LIMIT SWITCH



DSL SPARE



ADDRESS

+91 9195962323

+91 7588880747

pranit@bhagwatimachines.com

Info.cranes@bhagwatimachines.com

HEAD OFFICE (AJMER)

178, 179, 179-A, RIICO Industrial Area Extn,
Parbatpura-Makhupura, AJMER (Raj)

DELHI OFFICE

YC CO-WORKING SPACE 4TH FLOOR, PLOT NO-94 SEC-13,
NEAR RADISSON BL NEW DELHI-110078

PUNE (MAHARASHTRA)

Shop No. - 104, Westwood Estate, 235/2A,
Chhatrapati Chowk, Kaspte Vasti, Wakad, Pune-57

BENGALURU (KARNATAKA)

1F, Maa Tara Apartments, 4th Floor Srirampura,
Bommasandra, Jigni Road Bengaluru (Karnataka)

PALANPUR (GUJRAT)

District Banaskantha,
Palanpur (Gujarat)

KARIMNAGAR (TELANGANA)

Shree Niwasa Complex, Kazipur Road,
Bahupet, Karimnagar (Telangana)

SRIKAKULAM (ANDHRA PRADESH)

H. No 4-12, Sai Nagar, Narasannapeta,
Srikakulam (Andhra Pradesh)

KISHANGARH (RAJASTHAN)

Studio Flat No. C-1, 3rd Floor, Ganpati Square,
RIICO Industrial Area Madanganj-Kishangarh (Raj)